



Tianjin Xinruifeng Technology Co., Ltd.
www.tj-xrf.com



Tianjin Xinruifeng Technology Co., Ltd.

Add.: BLD No.1 , #20 Fourth Fengze Road, Balitai Industrial Park, Jinnan District, Tianjin China 300350

No.10, Keda 2nd Road, Balitai Town, Jinnan District, Tianjin China 300350

Web: www.tj-xrf.com

Mr. Frank Yang (Account Manager)

Mobile/ WeChat/ WhatsApp/VK: +86 13388086083

Email: frank@tj-xrf.com



PROFESSIONAL & PREMIUM MANUFACTURER OF SCREWS & FASTENERS





Tianjin Xinruifeng Technology Co., Ltd., was established in 2008 and its business covers fastener design, manufacturing and export. We have 3 production bases, with a total area of 16,000 square meters. Our main products include drywall screws, chipboard screws, self-drilling screws and self-tapping screws. We can also supply other fasteners like nails, staples, blind rivets, anchors, hose clamp, bolts and nuts.

We have 280 sets of automatic production equipments, including wire drawing machines, cold-heading machines, thread rolling machines, tailing machines and heat-treatment lines. We are your one-stop manufacturer from raw material to final products. Our annual production capacity reaches up to 30,000 tons, 70% of which are exported to different countries and regions.

Tianjin Xinruifeng Technology Co., Ltd. has been in the fastener industry for nearly 15 years and we can customize all kinds of products per your requirements. We have an established management system and quality control procedure. Excellent quality, competitive price and timely delivery are the pillars of the company's foundation. Win-win and long-term cooperation are our final goals when dealing with different clients.

Company Feature:

1. Professional & Premium Manufacturer of Screws and Fasteners in China from 2008
2. Company Area-16000SQ
3. Three Factories: Ten Workshops+Three Warehouse
4. 280 sets of Premium production Equipments from Taiwan & Germany
5. Professional R&D and QC Team: R&D Engineer*8 People+QC Engineer*10 People
6. Production according to standard of ISO, DIN, GB, JIS or customer



Cold -Heading Workshop



Thread Rolling Workshop



Point Forming Workshop



Heat-Treatment Workshop



Cold-Heading Workshop



Marketing office on the 3rd Floor

1. Premium Production Equipment*280sets
2. Workshop*10 (Drawing*1+Heading*2+Tailing*1+Thread Rolling*2+Heat Treatment*1+Packaging*3)
3. Warehouse*3
4. Office Building*2 and 3 floors/Building

SCREW PRODUCTION PROCESS:



1. Perfect Production Process-Imported from Taiwan and Germany etc
2. Production Process Engineer x3 people
3. Average Working Experience- 20 Year

TECHNOLOGY RESEARCH & DEVELOPMENT:



1. Premium Production Equipment- Imported from Taiwan and Germany etc.
2. Production Equipment Engineer x5people and Average Working Experience- 20 Years.

QUALITY CONTROL:



1. Professional QC stuff*10 people
2. Test at each step of full production process
3. Premium test instruments

General Manager



- 1. More than 100 Employees
- 2. 6 Senior Engineers
- 3. 30 employees with Bachelor Degree
- 4. R&D Department: 8 Engineers
- 5. QC Department: 10 Engineers
- 6. Production Dept.: 80 Workers

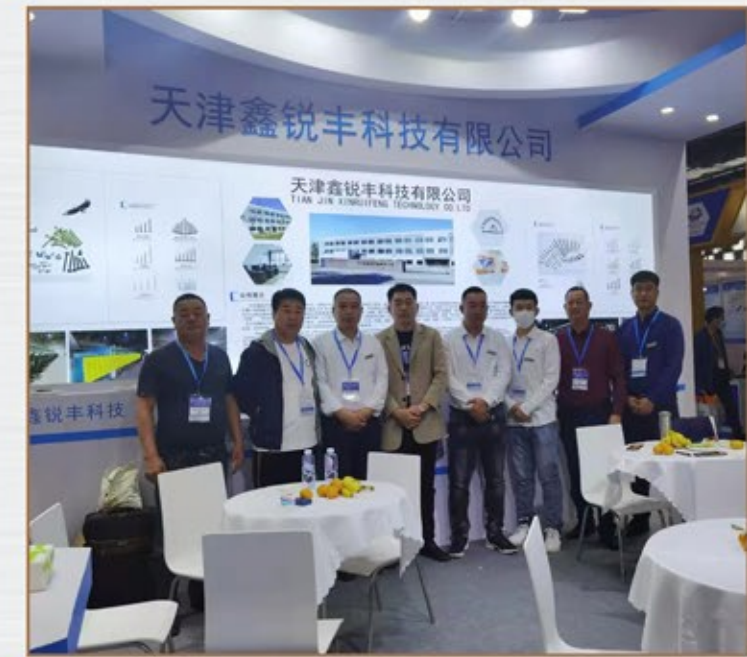

- 1. We usually attend Expo like Shanghai Fastener Show and Koelnmesse etc.
- 2. We also show our company via Made-in-China and YouTube etc.

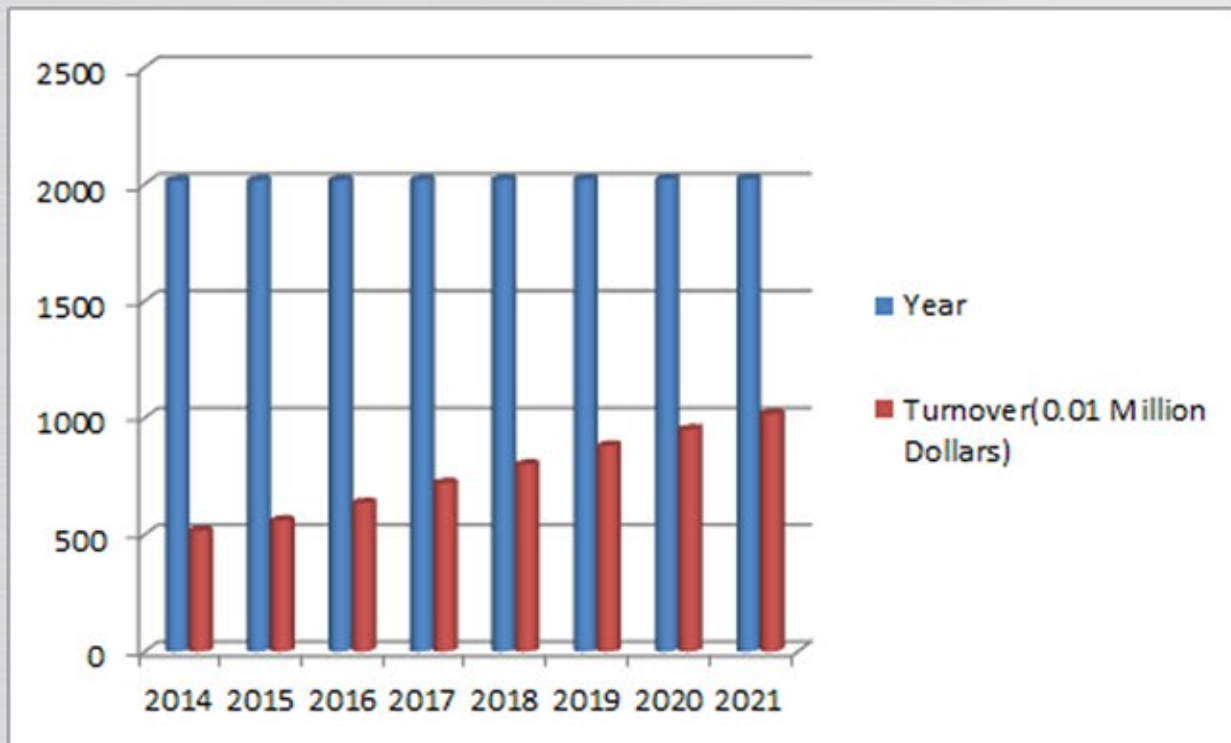

- 1. Xinruifeng have been gradually accepted and recognized by oversea customers
- 2. Xinruifeng turnovers have increased steadily in the past eight years
- 3. Mainly export to Russia and countries in Southeast Asia, South Asia, American etc.



CE Certificate



SGS Certificate



CE Certificate

- 1. CE Certificate*2
- 2. SGS Certificate*4
- 3. Trademark Certificate*2

FEATURE PRODUCTS



NAME: PAN FRAMING SELF DRILLING SCREW
DIA: M3.5(#6)/ M3.9(#7)
LENGTH: From 9.5mm to 13mm
FINISH: Black/Grey Phosphated
MATERIAL: C1022A



NAME: PAN FRAMING SELF DRILLING SCREW
DIA: M3.5(#6)/ M3.9(#7)
LENGTH: From 9.5mm to 13mm
FINISH: White/Yellow Zinc Plated
MATERIAL: C1022A



NAME: OVAL ROUND SELF TAPPING SCREW
DIA: M3.5(#6)/ M3.9(#7)/ M4.2(#8)
LENGTH: From 9mm to 30mm
FINISH: Black/Grey Phosphated
MATERIAL: C1022A



NAME: OVAL ROUND SELF TAPPING SCREW
DIA: M3.5(#6)/ M3.9(#7)/ M4.2(#8)
LENGTH: From 9mm to 30mm
FINISH: White/Yellow Zinc Plated
MATERIAL: C1022A

FEATURE PRODUCTS



NAME: FINE THREAD BUGEL HEAD DRYWALL SCREW
DIA: M3.5(#6)/ M3.9(#7)/ M4.2(#8)/ M4.8(#10)
LENGTH: From 13mm(1/2") to 254mm(10")
FINISH: Black/Grey Phosphated
MATERIAL: C1022A



NAME: COARSE THREAD BUGEL HEAD DRYWALL SCREW
DIA: M3.5(#6)/ M3.9(#7)/ M4.2(#8)/ M4.8(#10)
LENGTH: From 13mm(1/2") to 254mm(10")
FINISH: Black/Grey Phosphated
MATERIAL: C1022A







NAME: FINE THREAD BUGEL HEAD DRYWALL SCREW
DIA: M3.5(#6)/ M3.9(#7)/ M4.2(#8)/ M4.8(#10)
LENGTH: From 13mm(1/2") to 254mm(10")
FINISH: White/Yellow Zinc Plated
MATERIAL: C1022A



NAME: CHIPBOARD SCREW
DIA: M3.0/ M3.5/ M4.0/ M4.5/ M5.0/ M6.0
LENGTH: From 9mm (3/8") to 254mm (10")
FINISH: White/Yellow Zinc Plated
MATERIAL: C1022A







DRYWALL SCREWS



Head type:	
	Bugle Head
Drive:	
	Phillips Drive
Thread type:	 
	Coarse Thread Fine Thread
Diameter:	M3.5(#6) / M3.9(#7) / M4.2(#8) / M4.8(#10)
Length:	From 13mm(1/2") to 254mm(10")
Material:	C1022A
Finish:	Black/Grey Phosphated, White/Yellow Zinc Plated



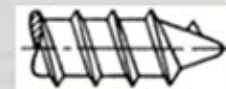
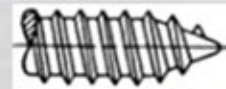

SELF TAPPING SCREWS



Head type:	    
	CSK Pan Truss Hex Pan Framing
Drive:	 
	Phillips Pozi
Thread type:	 
	Type A Type AB
Diameter:	M3.5(#6) / M3.9(#7) / M4.2(#8) / M4.8(#10) / M5.5(#12) / M6.3(#14)
Length:	From 9mm (3/8") to 254mm (10")
Material:	C1022A, SS304
Finish:	White/Yellow Zinc Plated, Nickel Plated, Dacromet, Ruspert









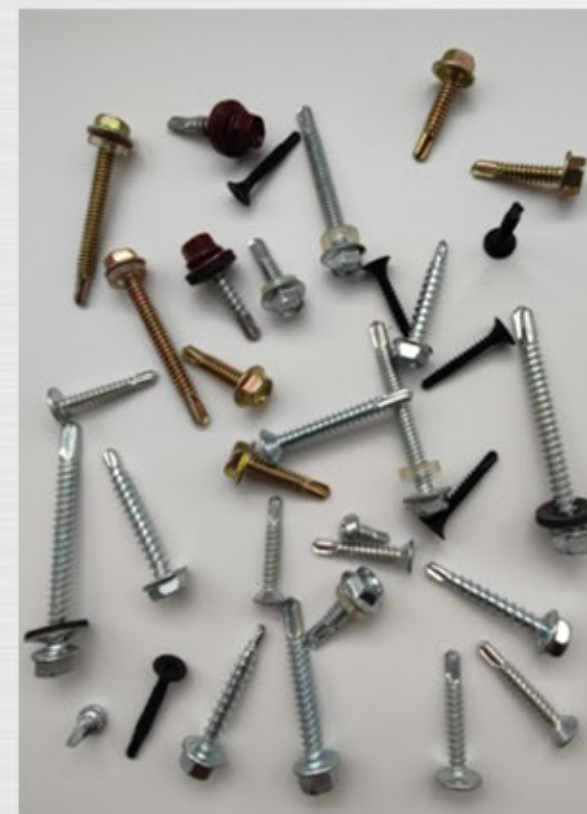



CHIPBOARD SCREWS

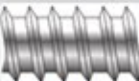
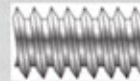

Head type:	
	Countersunk Head
Drive:	  
	Phillips Pozi Square
Thread type:	
	Single Thread
Diameter:	M3.0 / M3.5 / M4.0 / M4.5 / M5.0 / M6.0
Length:	From 9mm (3/8") to 254mm (10")
Material:	C1022A
Finish:	White/Yellow Zinc Plated

SELF DRILLING SCREWS



Head type:	    
	CSK Pan Truss Hex Pan Framing
Drive:	 
	Phillips Pozi
Thread type:	  
	Type A Type B Type C
Point type:	  
	TEKS Type 17 Wing TEKS
Diameter:	M3.5(#6) / M3.9(#7) / M4.2(#8) / M4.8(#10) / M5.5(#12) / M6.3(#14)
Length:	From 9mm (3/8") to 254mm (10")
Material:	C1022A, SS304
Finish:	White/Yellow Zinc Plated, Nickel Plated, Dacromet, Ruspert, Coating

WOOD SCREWS



Diameter:	M6-M20
Length:	16-300mm
Material:	Q235, C1022A
Finish:	Zinc Plated, HDG

CONCRETE SCREWS

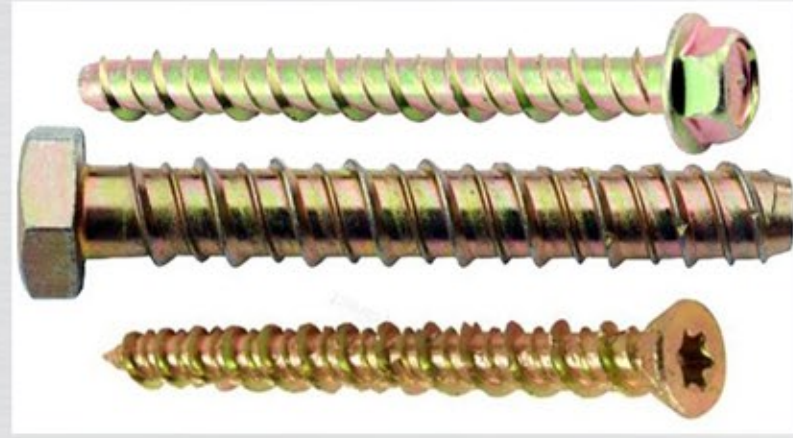

Diameter:	M6-M20
Length:	16-300mm
Material:	Q235
Finish:	Zinc Plated, HDG

COMMON NAILS



Diameter:	Gauge16-Gauge2
Length:	1/2"-8"
Material:	Q235
Finish:	Zinc Plated, Polish, HDG

PLASTIC CAP NAILS



Diameter:	Gauge12-Gauge11
Length:	3/4"-3"
Material:	Q235
Finish:	Zinc Plated

COLLATED SCREWS



Diameter:	M3.5-M4.8
Length:	13-32mm
Material:	C1022A, Q235
Finish:	Zinc Plated, Black/Grey Phosphated

SANDWICH PANEL SCREWS



Diameter:	M5.5-M10
Length:	50-250mm
Material:	C1022A, Q235
Finish:	Zinc Plated, HDG, Dacromet, Ruspert

COIL NAILS



Diameter:	M2.1-M4.0
Length:	3/4" to 4"
Material:	Q235, SS304
Finish:	Zinc Plated, Polish, HDG, Coating

COIL ROOFING NAILS



Diameter:	M3.05
Length:	3/4" to 1-3/4"
Material:	Q235
Finish:	Zinc Plated, Polish, HDG, Coating

GAS PIN NAILS



Diameter: 2.7mm to 3.3mm
Length: 19mm to 32mm
Material: #60 Steel
Finish: Zinc Plated, HDG, Coating

CONCRETE NAILS



Diameter: 1.2mm to 5.0mm
Length: 1/2" to 10"
Material: #45 Steel, #50 Steel, #60 Steel
Finish: Zinc Plated, Polish, MG, HDG, Black Oxide

STAPLES



Diameter: 2.7mm to 3.3mm
Length: 19mm to 32mm
Material: #60 Steel
Finish: Zinc Plated, HDG, Coating

BRAD NAILS



Diameter: 1.2mm to 5.0mm
Length: 1/2" to 10"
Material: #45 Steel, #50 Steel, #60 Steel
Finish: Zinc Plated, Polish, MG, HDG, Black Oxide

BLIND RIVETS



Diameter: 3.0mm to 6.0mm
Length: 1/4" to 1-1/2"
Material: Aluminium & Magnesium Alloy
Finish: Zinc Plated, Color Painting Bakery

STRIP NAILS

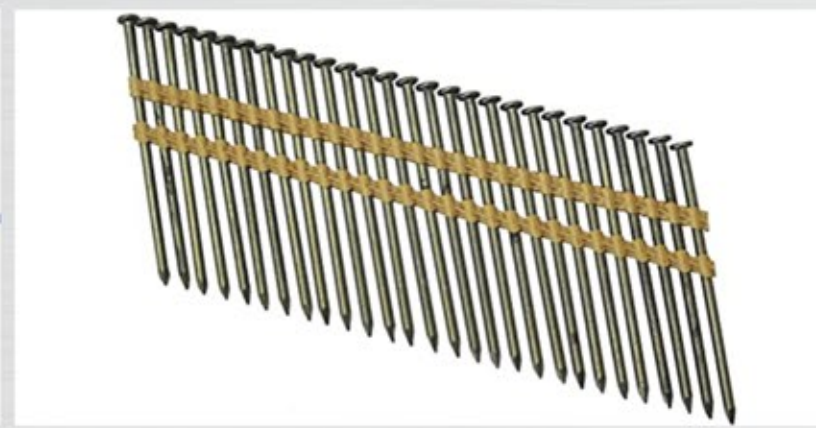

Diameter: 2.8mm to 4.1mm
Length: 1" to 3-1/2"
Material: Q235
Finish: Zinc Plated, Polish, HDG,

FLOORING NAILS

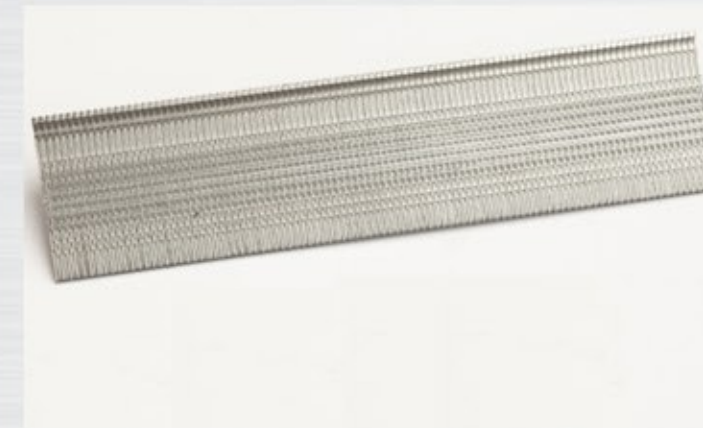

Diameter: Gauge 20 to gauge 16
Length: 1-1/4" to 2"
Material: Q235
Finish: Zinc Plated, Color Painting

CARTON CLOSING STAPLES



Diameter: Gauge 20 to gauge 16
Length: 3/8" to 7/8"
Material: Q235
Finish: Zinc Plated, Color Painting, Copper Plated